

60CC MINI SWIFT USA - TAG

|  | | FEATURES | |
|--|-------------------------------------|-----------------------------------|---------------------------|
| | | Cylinder Volume | 60.00 cm ³ max |
| | | Bore | 41.80 mm |
| | | Max. bore | 42.07 mm |
| | | Stroke | 43.15 mm max |
| | | Cooling system | Air |
| | | Inlet system | Piston valve |
| | | Number of carbs | 1 |
| Tillotson Carburettor | HW-31A (Venturi Ø17mm) | Cylinder / crankcase transfers n° | 2 / 2 |
| Number of piston rings | 1 | Inlet / exhaust ports number | 1 / 1 |
| Big end conr. ball-bearing diam. | 18x24x15 | Combustion chamber shape | Spherical |
| Crankshaft ball-bearing diam. | 20x47x14 | Selettra ignition (adjustable) | Analogue 2 Poles |
| Small end conr. ball-bearing diam. | 12x16x16 | Distance between Conrod centers | 88 mm |

| DESCRIPTION OF THE MATERIAL | | PISTON | |
|-----------------------------|-------------|---|--|
| Conrod material | Steel |  <p>Min Weight (ring included) 60 g</p> | |
| Crankshaft material | Steel | | |
| Head Material | Aluminum | | |
| Cylinder Material | Aluminum | | |
| Liner material | Cast Iron | | DISTANCE BETWEEN CONROD CENTERS |
| Crankcase material | Aluminum | |  <p>Min Weight 80 g</p> |
| Piston material | Aluminum | | |
| Piston rings material | Cast Iron | | |
| Exhaust muffler material | Sheet-steel | | |
| Ball-bearings | 6204 type | | |

CRANKSHAFT

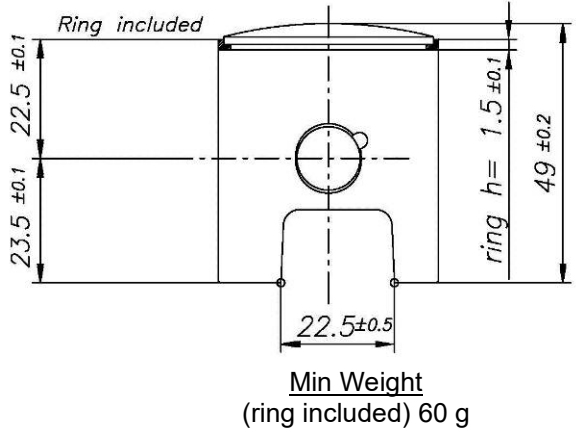
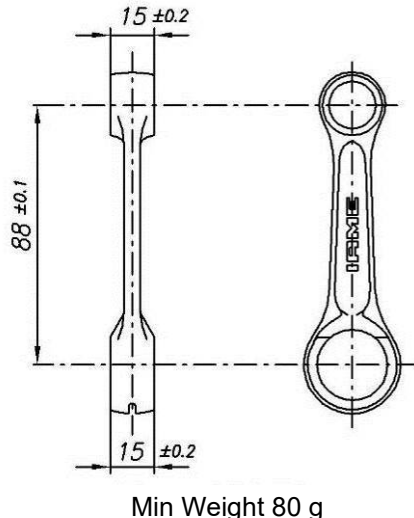
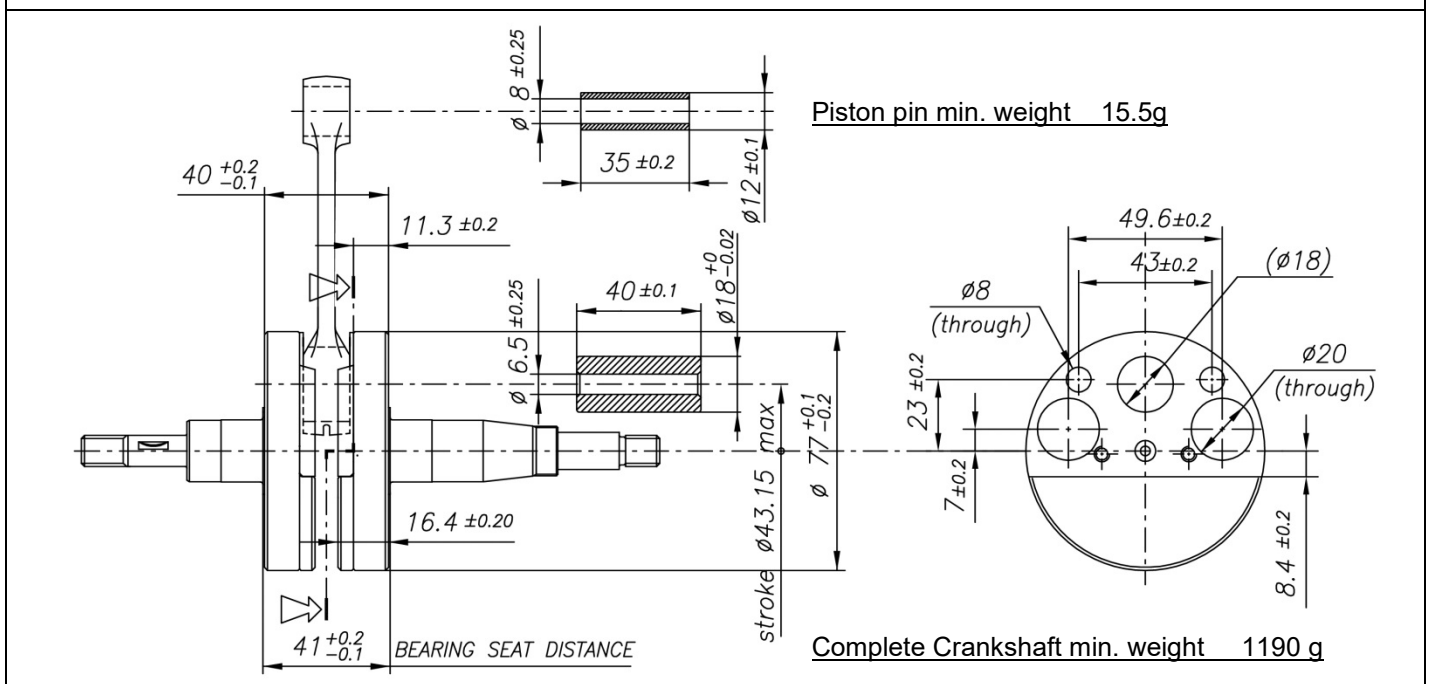

CYLINDER DEVELOPMENT

TOOL IAME Cod. 10194

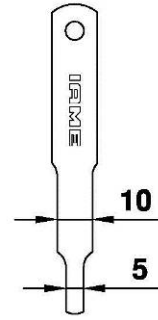
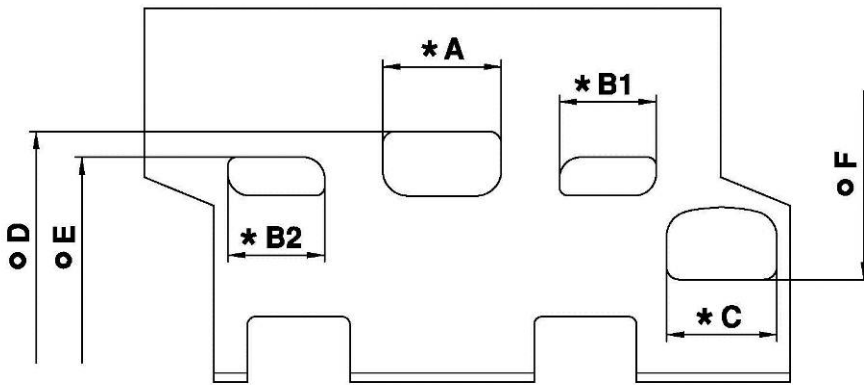

| | |
|---------|------------|
| A | ≤ 28.5 mm |
| B1 = B2 | ≤ 22.3 mm |
| C | ≤ 26.5 mm |
| D | 155.5° ±2° |
| E | 115.5° ±2° |
| F | 143.0° ±2° |

* CHORDAL READING

o ANGULAR READING BY INSERT A 0.2x5 mm GAUGE
USING IAME TOOL Cod. 10194

CYLINDER BASE VIEW

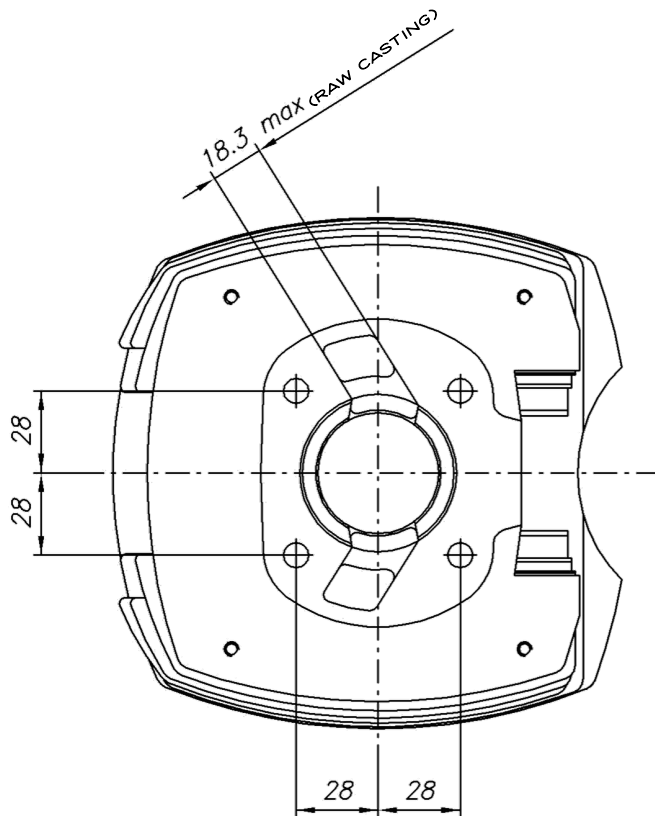

CYLINDER SECTION VIEW

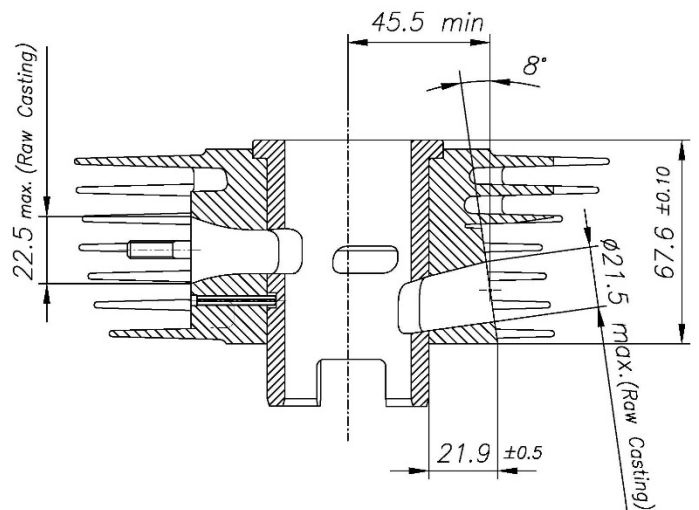

DISTANCE FROM EXHAUST FLANGE TO PISTON

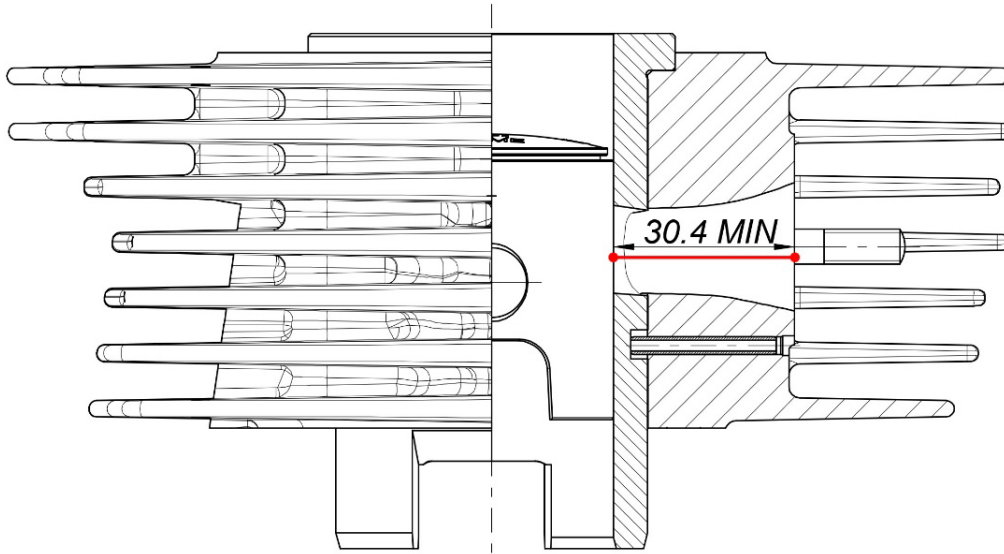

COMBUSTION CHAMBER VIEW

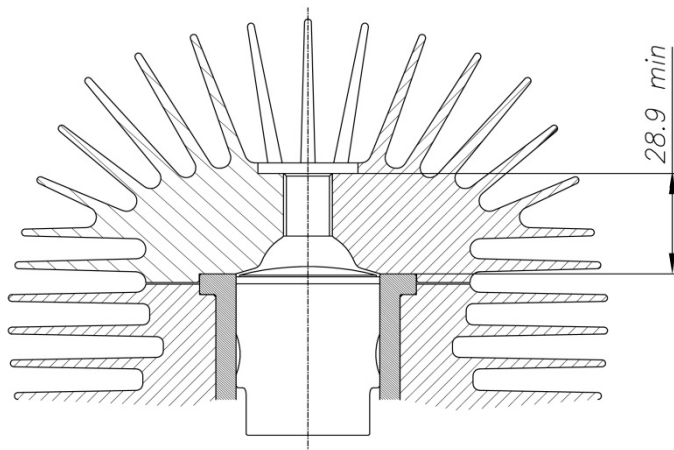

SQUISH MIN. = 0.025" (0.635 mm)
 (measured with 0.0625" (1/16") / Ø1.6mm solder)

CRANKCASE INSIDE VIEW

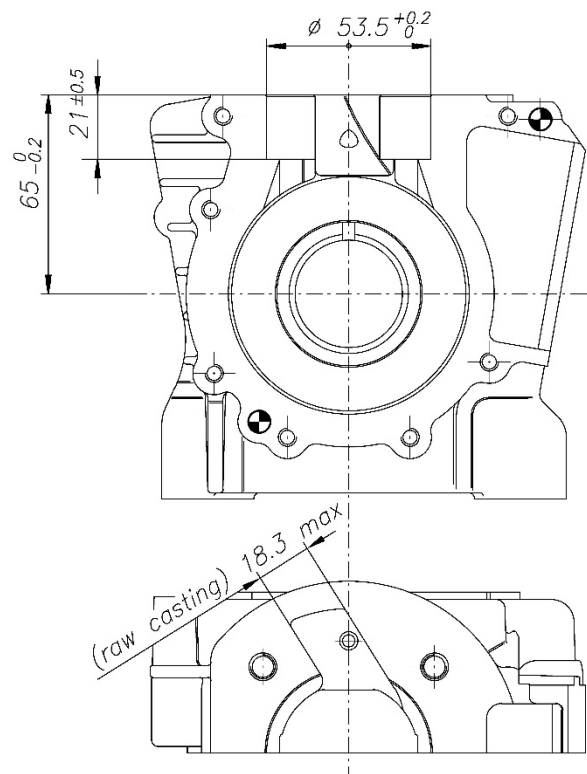

VENTURI CARB. DIMENSIONS and THERMAL SPACERS

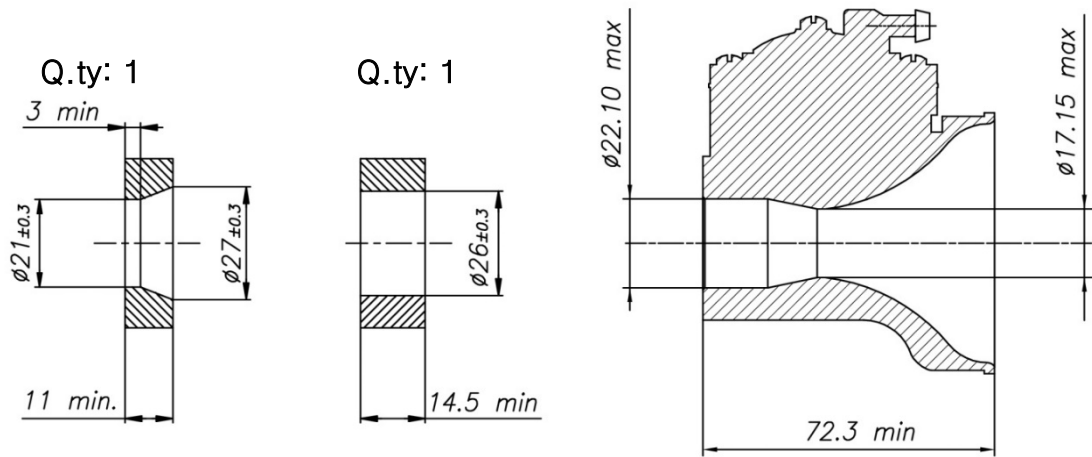

TILLOTSON MOD. HW-31A

INLET SILENCER

(CSAI OMOLOGATION N° 01/SA/14)

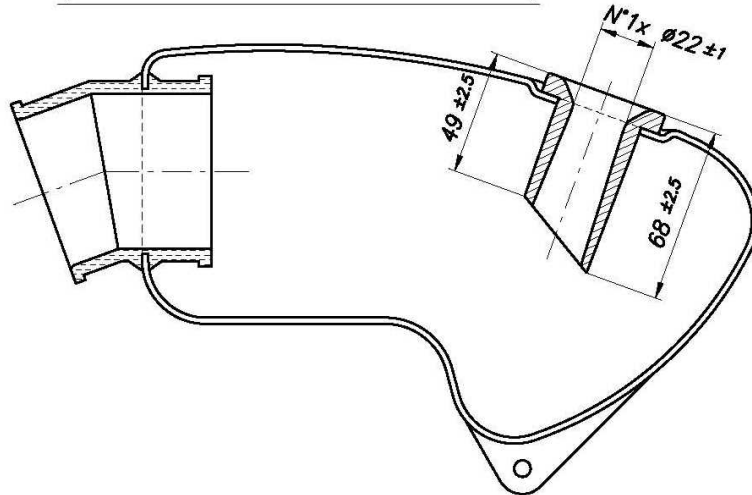

INLET SILENCER ALTERNATIVE MANIFOLD WITH SPONGE FILTER

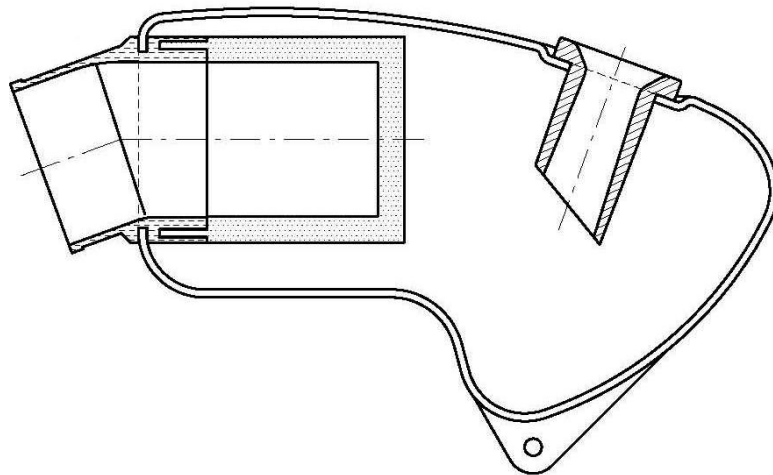

DESCRIPTION OF THE CLUTCH – TYPE1

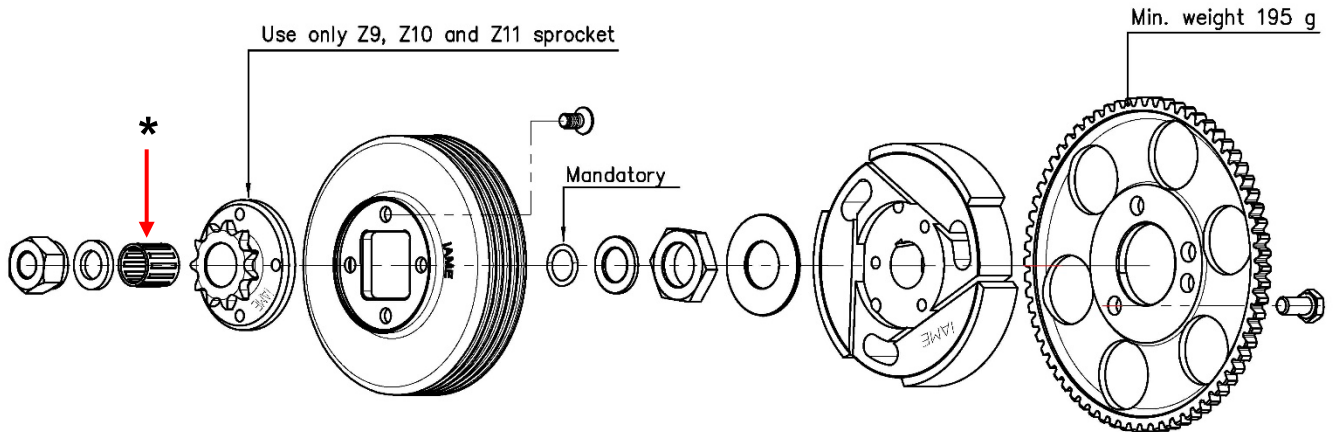

* When using the Z9, the roller cage is replaced by a bronze bushing, pressed into the sprocket

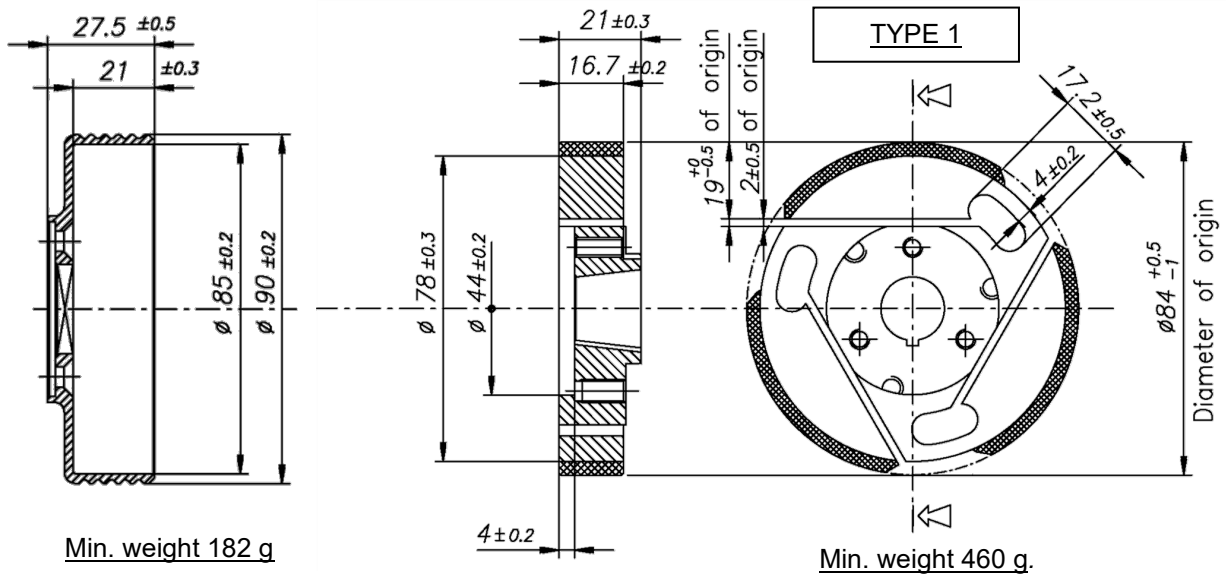

CLUTCH HUB IDENTIFICATION MARKING – TYPE 1

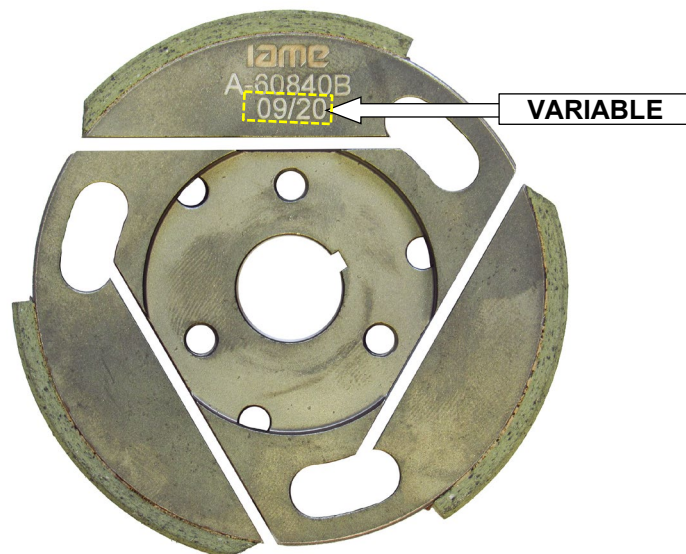

DESCRIPTION OF THE ALTERNATIVE CLUTCH – TYPE 2

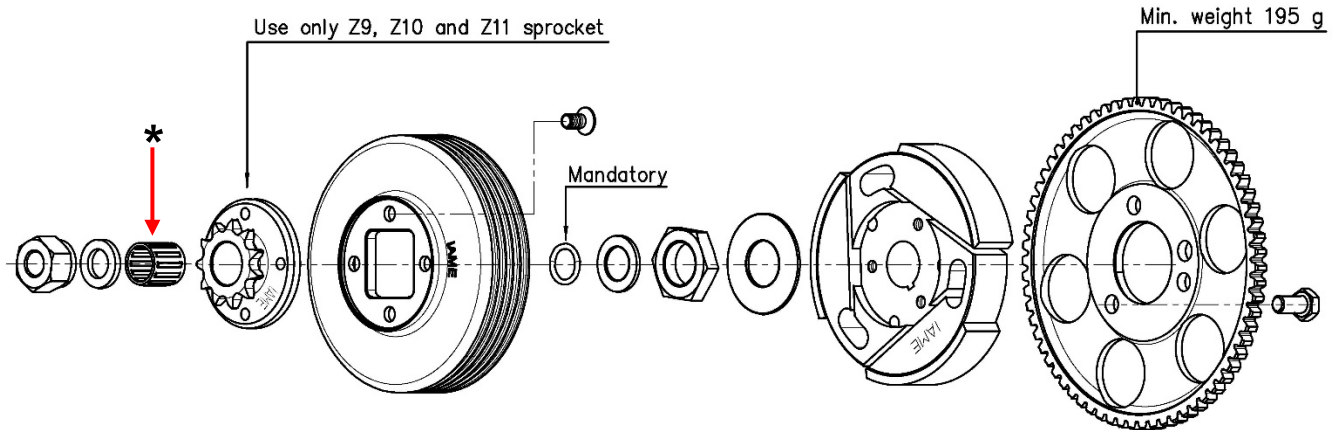

* When using the Z9, the roller cage is replaced by a bronze bushing, pressed into the sprocket

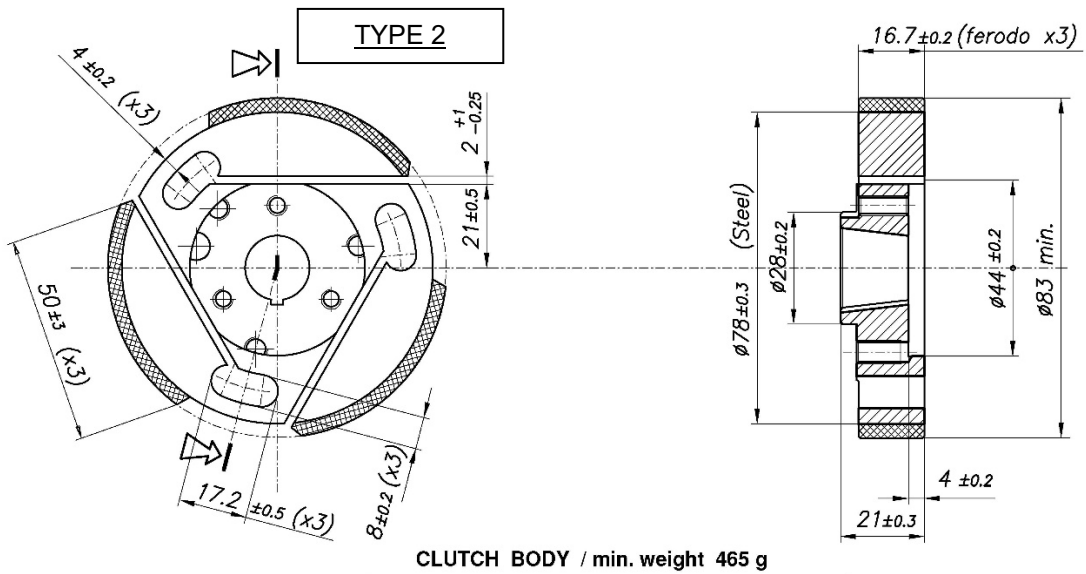

ALTERNATIVE CLUTCH HUB IDENTIFICATION MARKING – TYPE 2

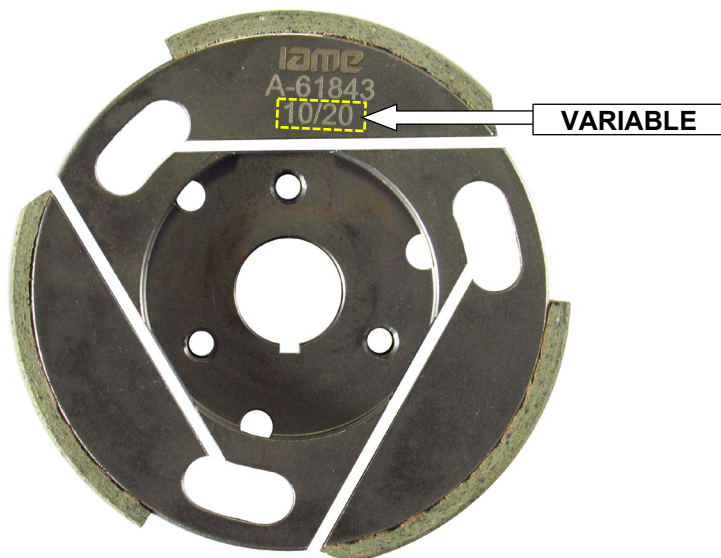

EXHAUST EXIT VIEW AND DIMENSION

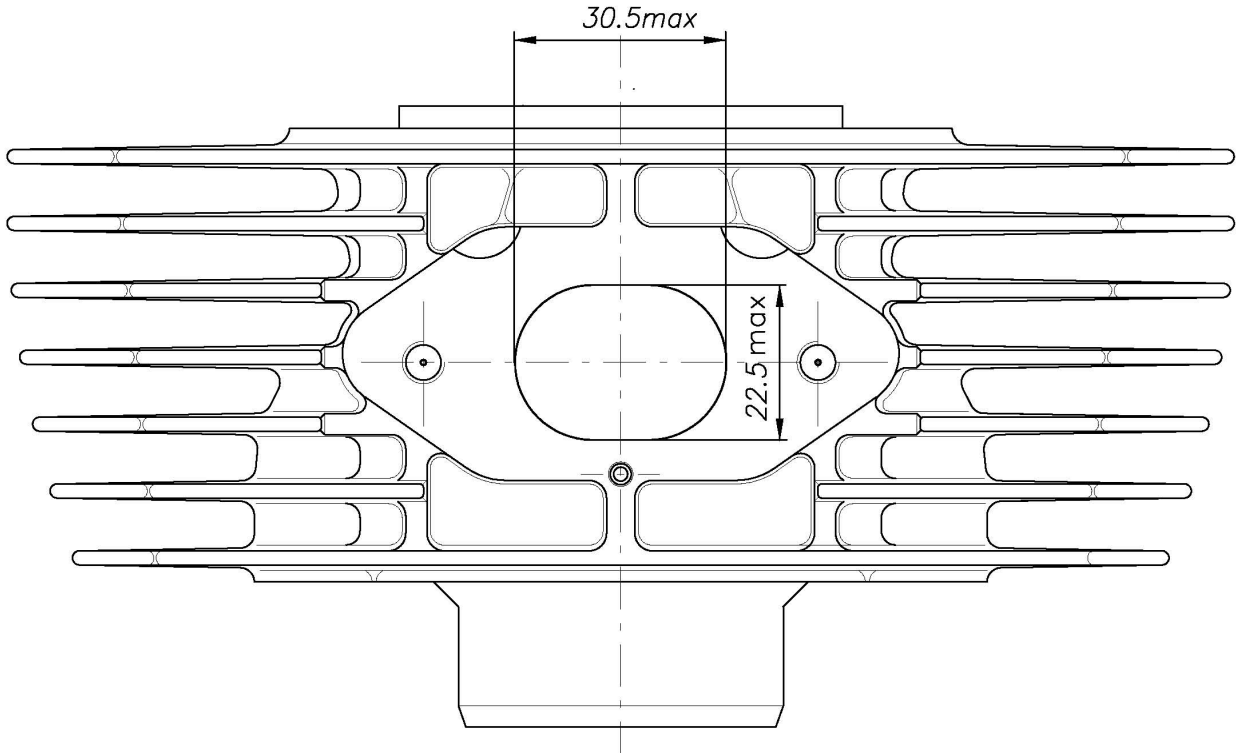

EXHAUST FITTING

Restricted

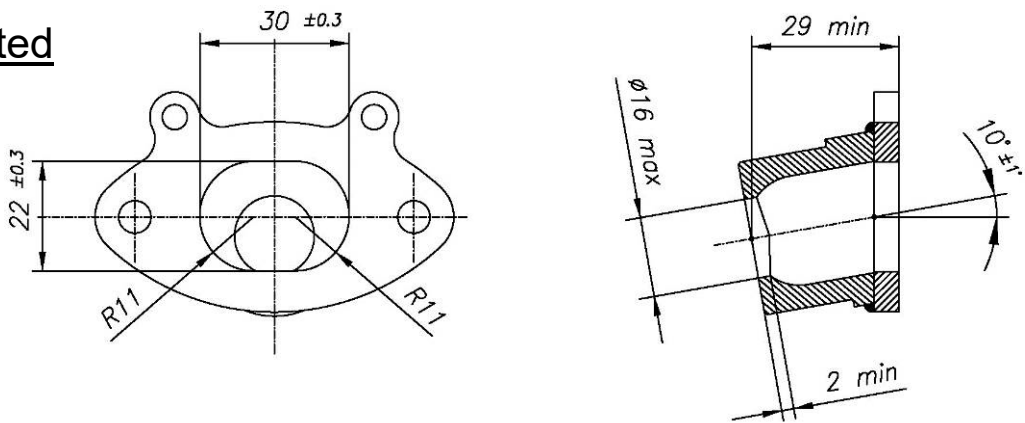

Unrestricted

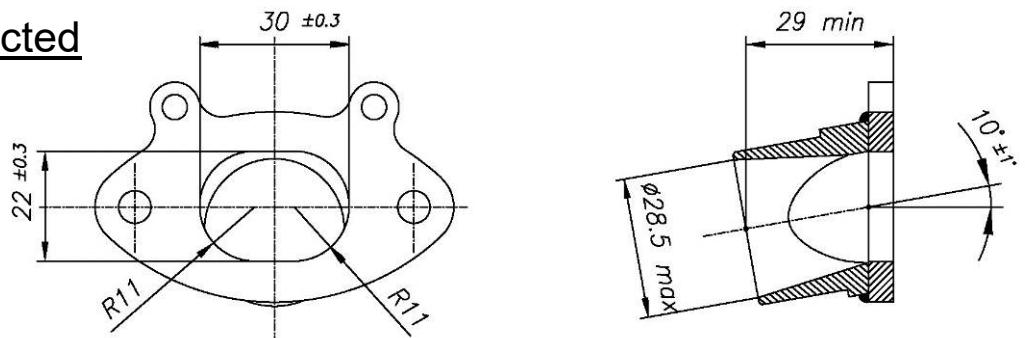

EXHAUST VIEW AND DIMENSIONS (with and without embossed logo)

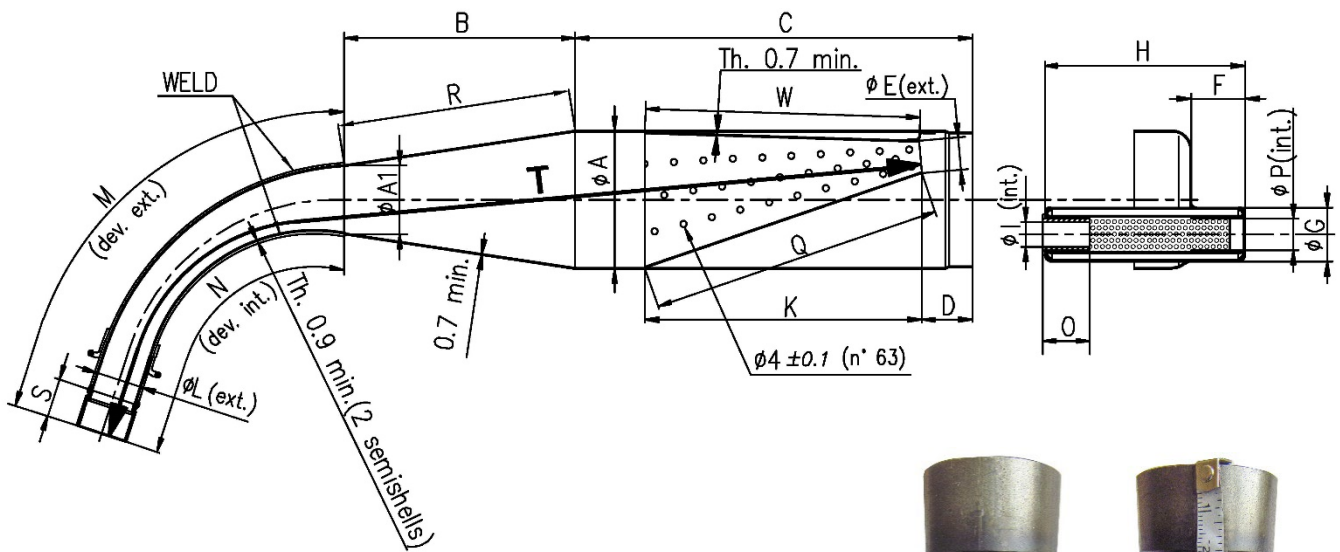

The tape must follow the centerline of the weld at all points

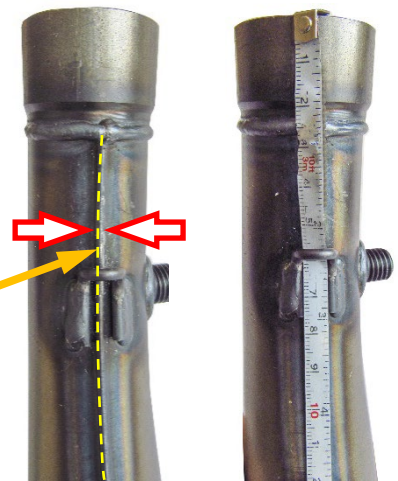

Min. weight 1.250 g

| | | | | | |
|---------------------------------------|-------------------------------------|---------------------------------------|-------------------------------------|-----------------------|-----------------------|
| ØA: $90 \pm 1.5 \text{ Øext.}$ | D: 30 ± 2 | H: 132 ± 2 | M: 265 ± 3 | R: 152 ± 3 | T: 601 ± 3 |
| ØA1: $45 \pm 1 \text{ Øext.}$ | ØE: $20 \pm 1 \text{ Øext.}$ | ØI: 17 max Øint. | N: 215 ± 3 | S: 25 ± 1 | |
| B: 150 ± 3 | F: 35 ± 2 | K: 181 ± 3 | O: 30 min. | Q: 192 ± 3 | |
| C: 260 ± 3 | ØG: $35 \pm 1 \text{ Øext.}$ | ØL: $31 \pm 1.5 \text{ Øext.}$ | ØP: $21 \pm 1 \text{ Øint.}$ | W: 181 ± 3 | |

WARNING:

The dimensions “**M**”, “**N**” and “**T**” must be taken by steel tape measure 6mm wide.

The dimensions “**M**” and “**N**” must be taken on the weld centerline.

The dimensions “**Q**” and “**W**” must be taken by steel tape measure 12mm wide

ALTERNATIVE EXHAUST with embossed logo



MARKING

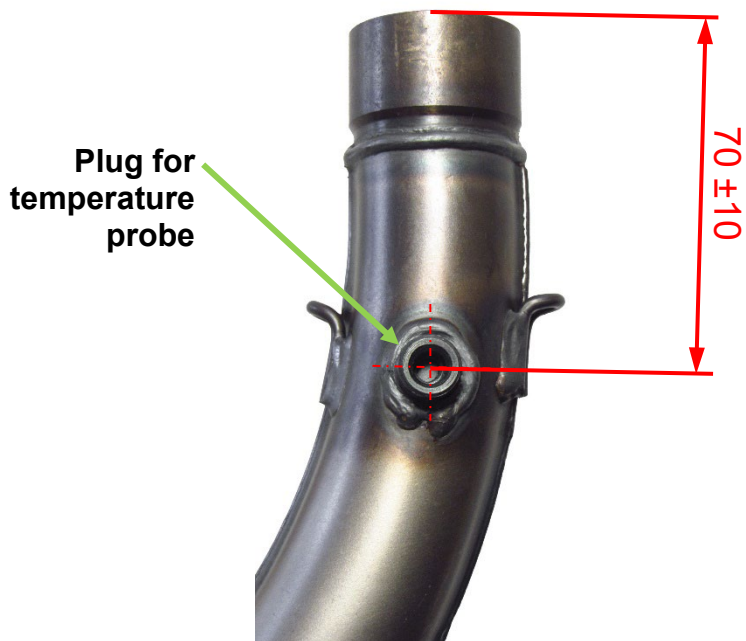

WIRING DIAGRAM

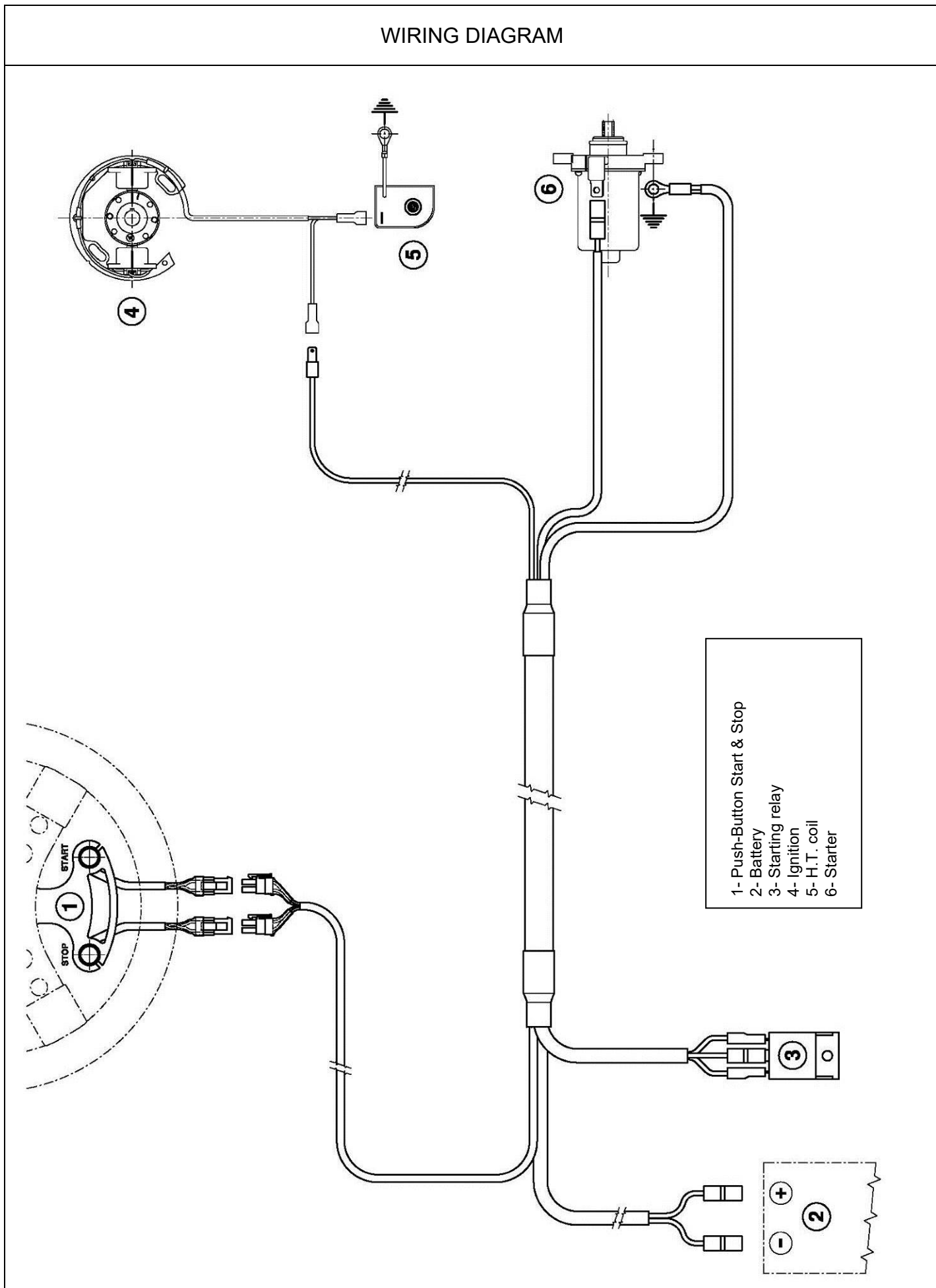

PHOTO COMPLETE WIRING

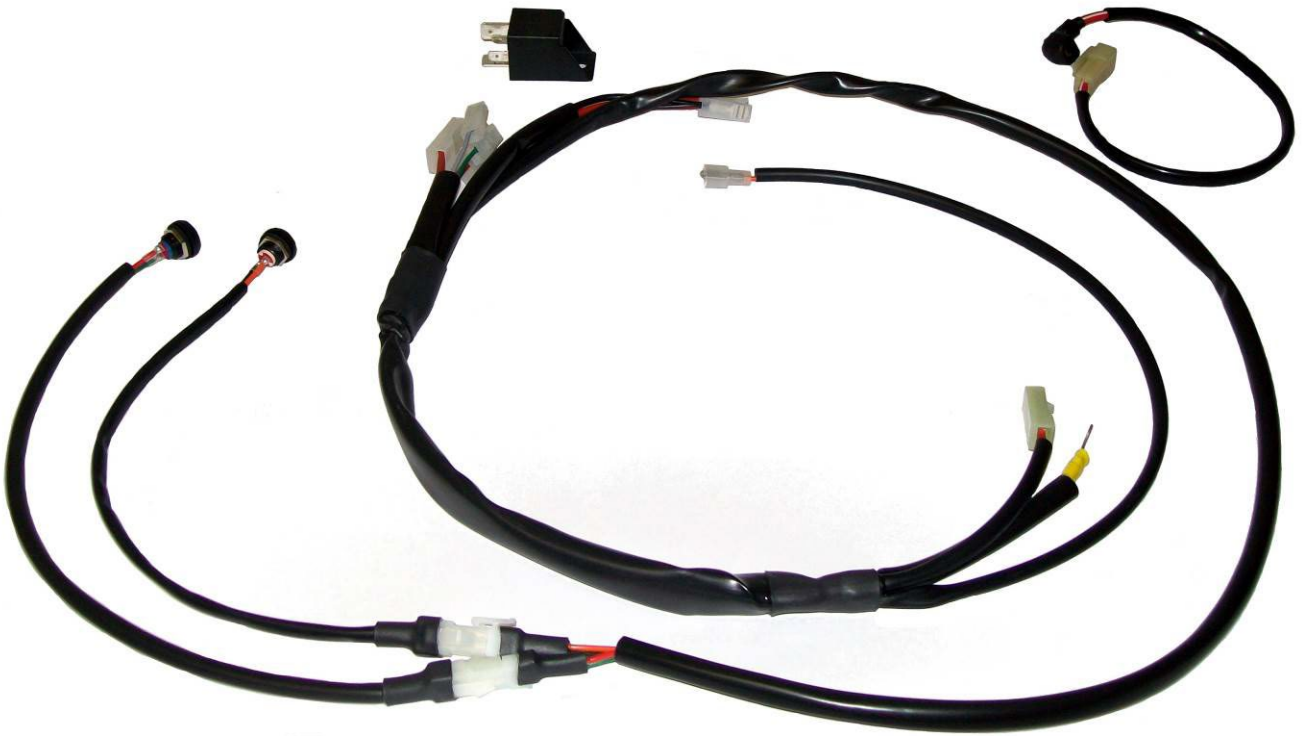
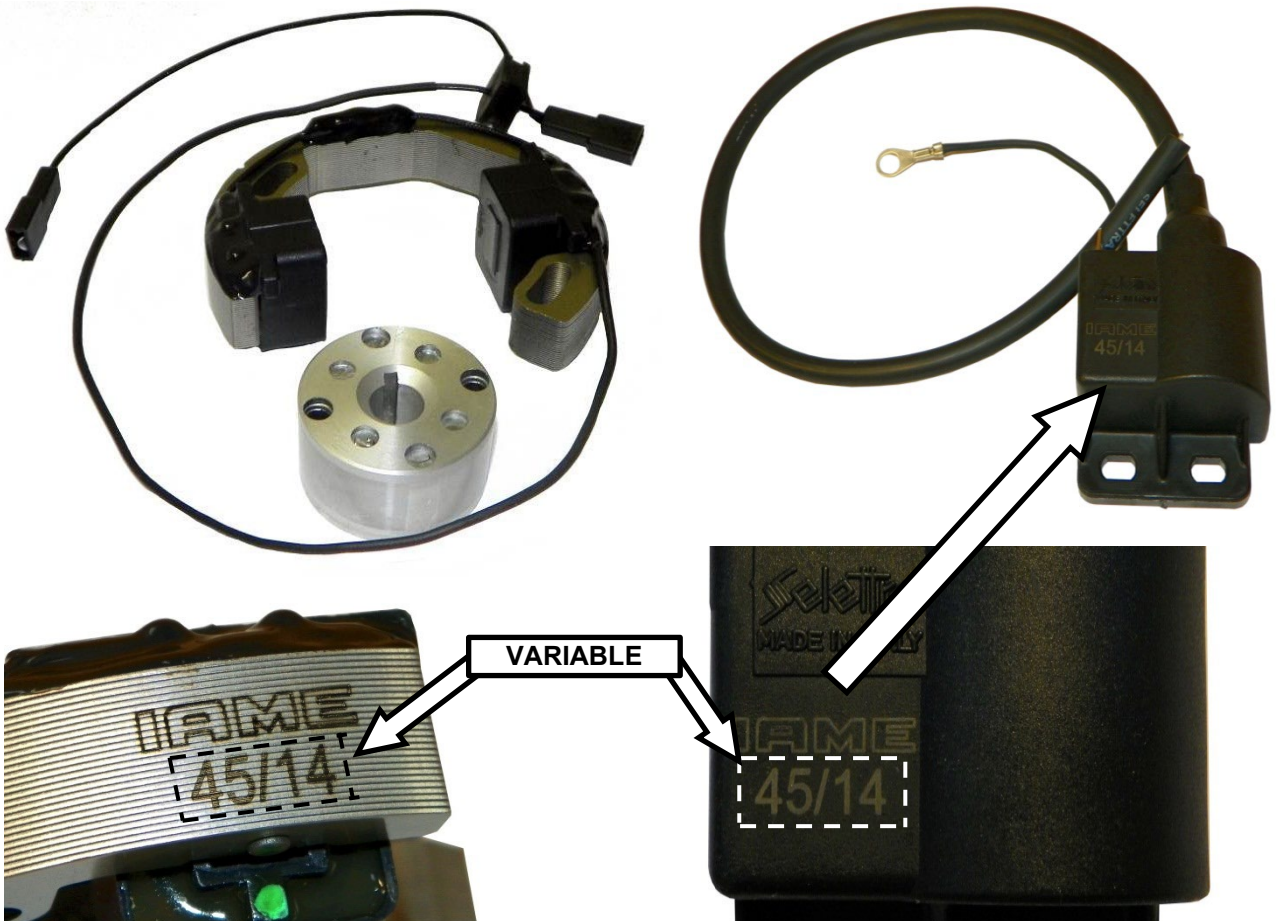

PHOTO OF IGNITION / PHOTO OF H.T. COIL (SELETTRA ANALOGUE 2 POLES)



ALTERNATIVE WIRING LOOM DIAGRAM

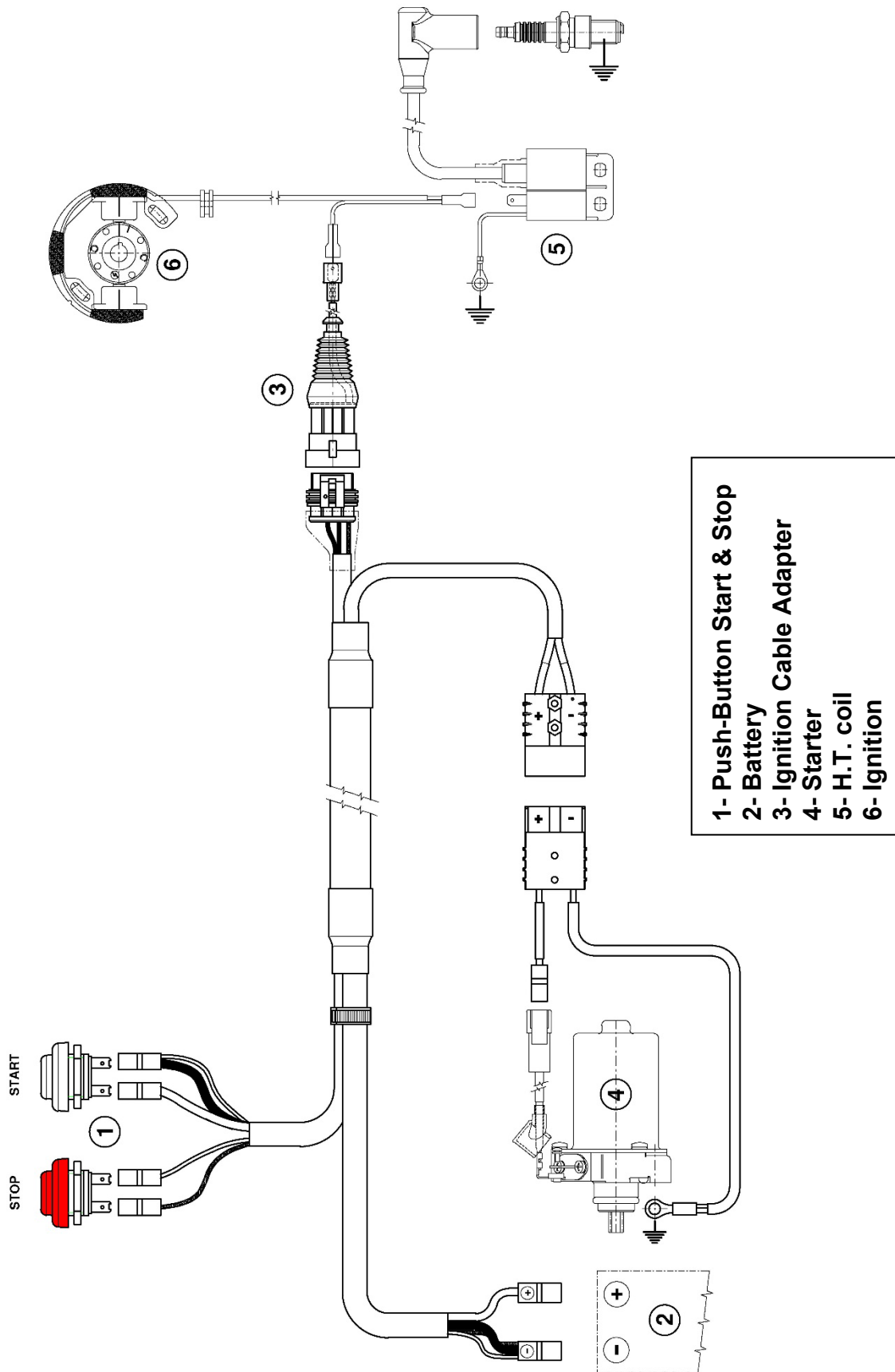
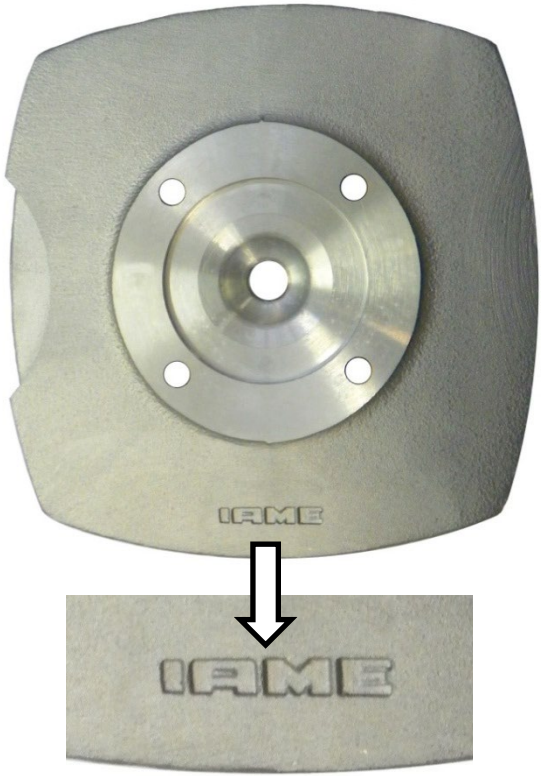

PHOTO OF ALTERNATIVE COMPLETE WIRING LOOM



HEAD IDENTIFICATION MARKING



CYLINDER IDENTIFICATION UPPER MARKING

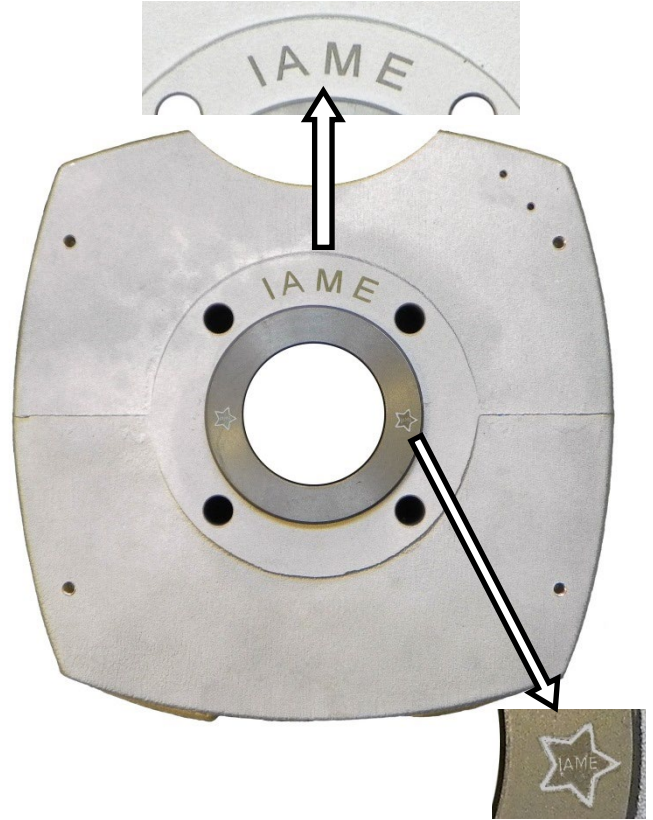

ENGINE STICKER "USA"



CYLINDER IDENTIFICATION LOWER MARKING

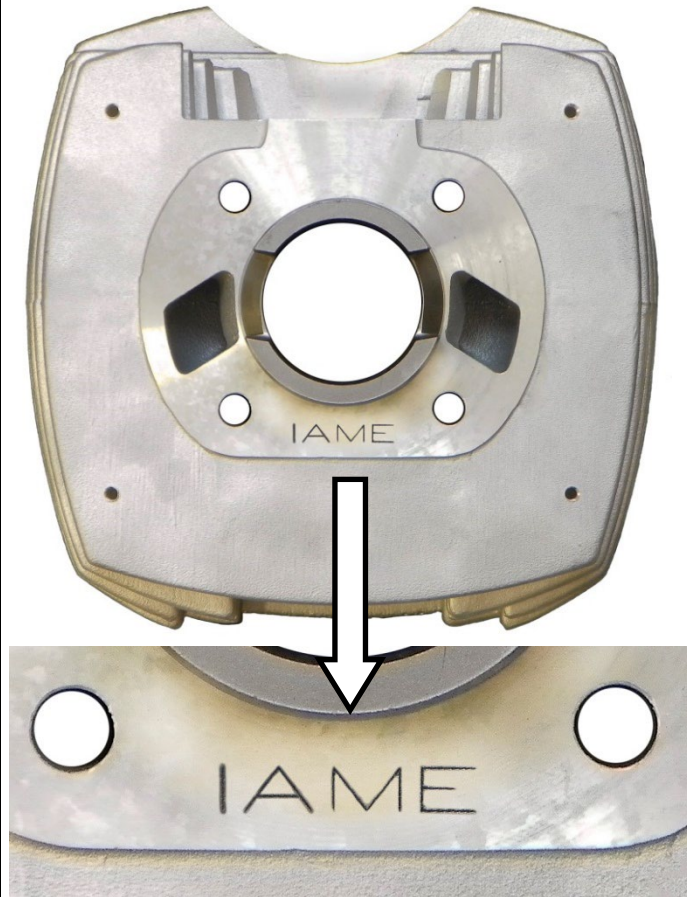

SEMICARTER IGNITION SIDE AND TRANSMISSION SIDE IDENTIFICATION MARKING

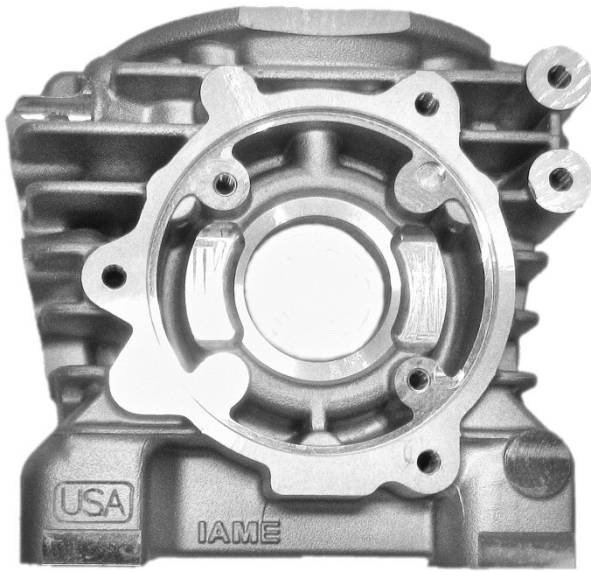

STARTER RING IDENTIFICATION MARKING

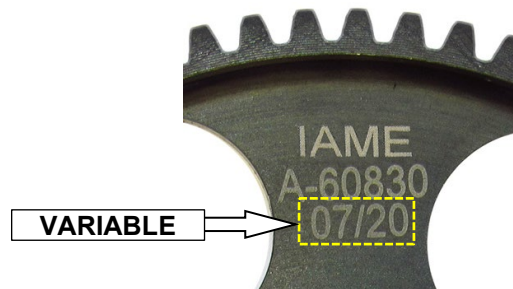

CRANKSHAFT IDENTIFICATION MARKINGS

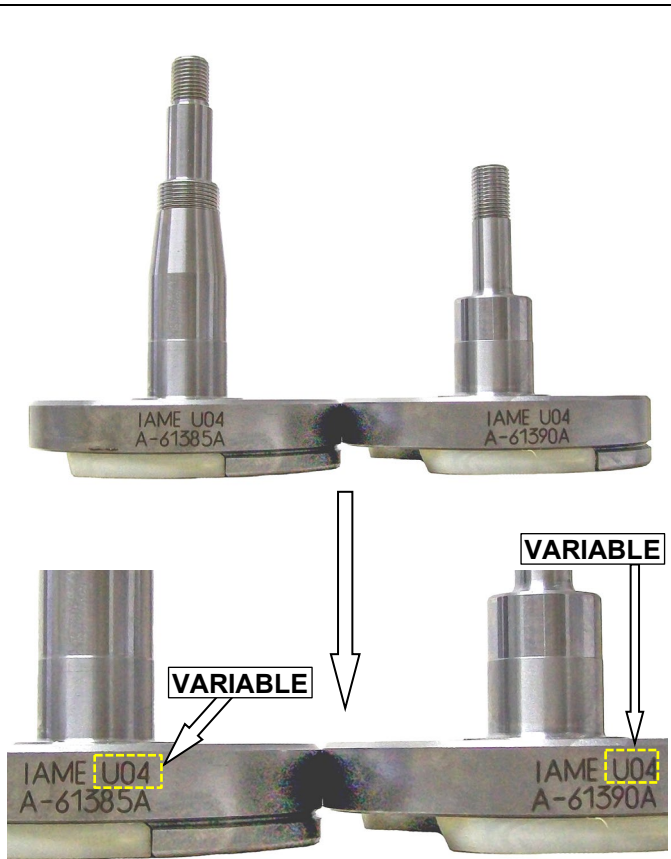

CONROD AND PISTON IDENTIFICATION MARKINGS

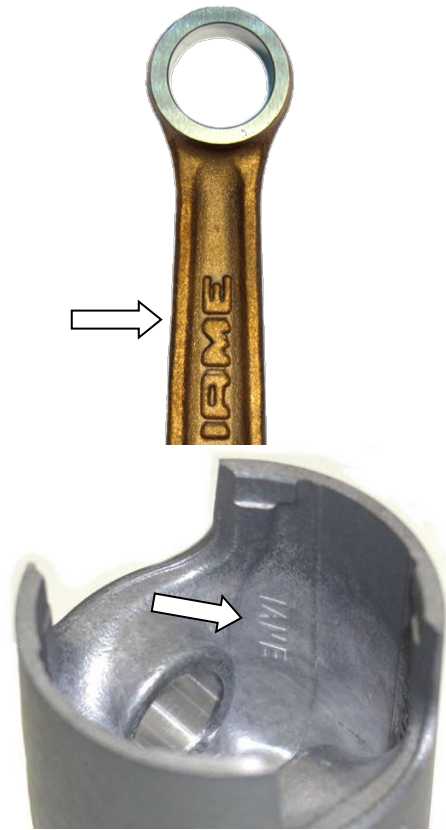

CLUTCH HUB IDENTIFICATION MARKING TYPE 1



CLUTCH DRUM IDENTIFICATION MARKING

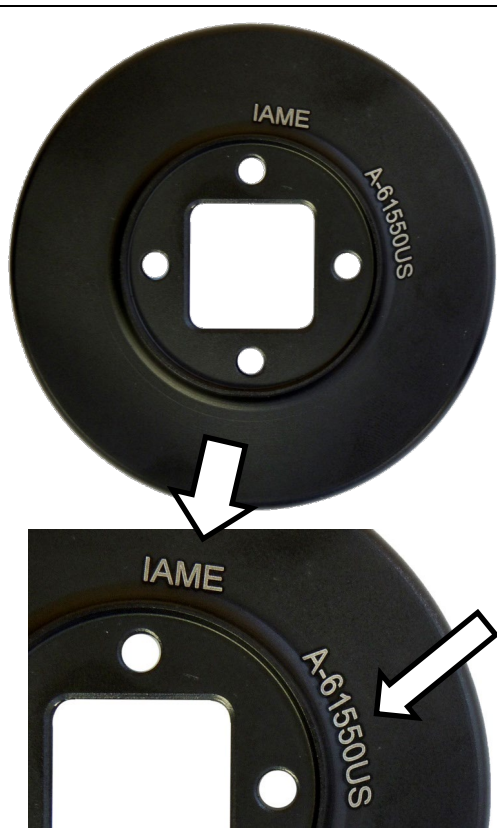

CRANKSHAFT PHOTOS

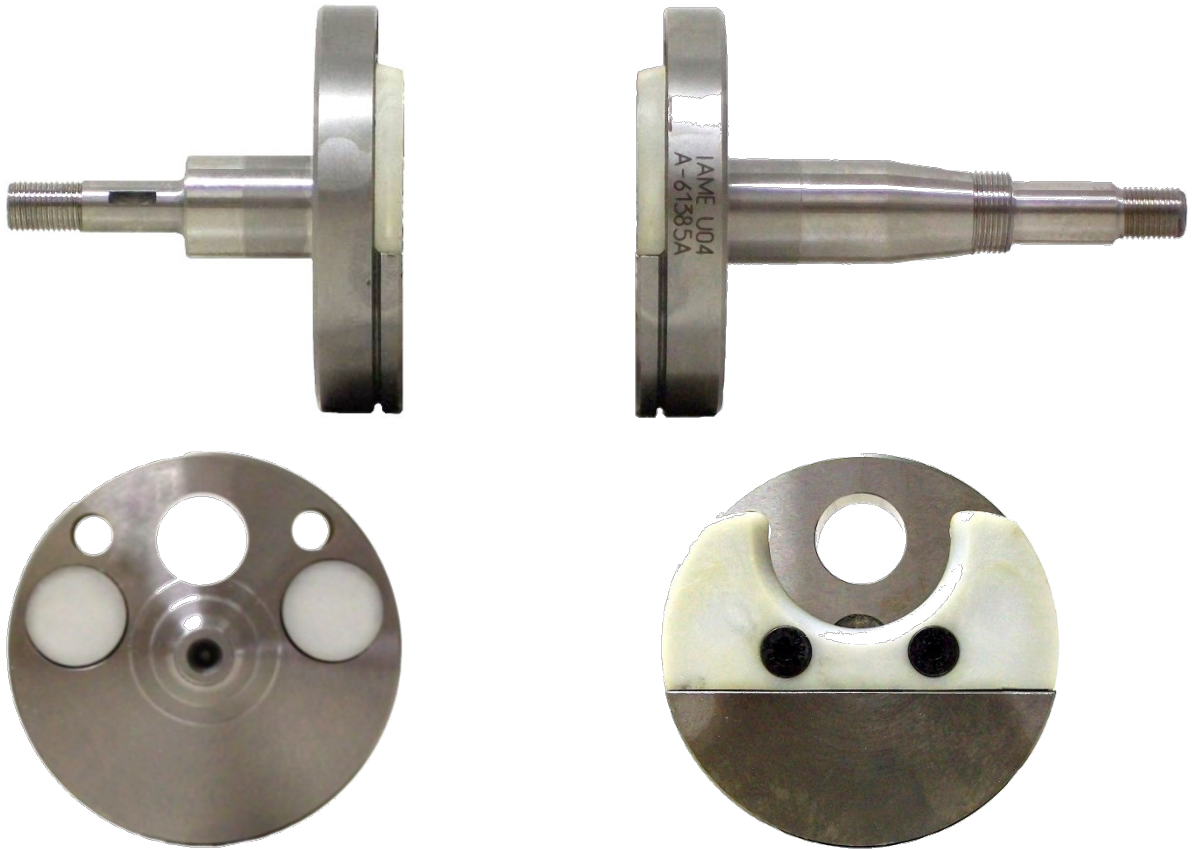
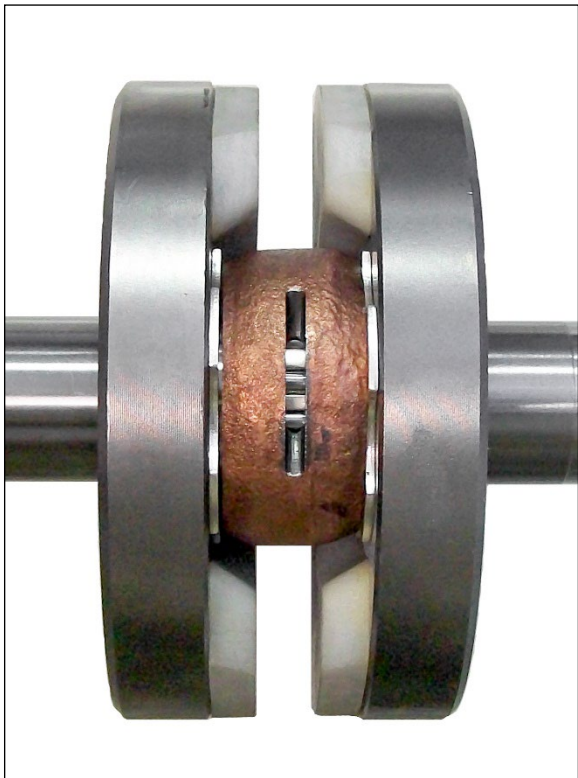
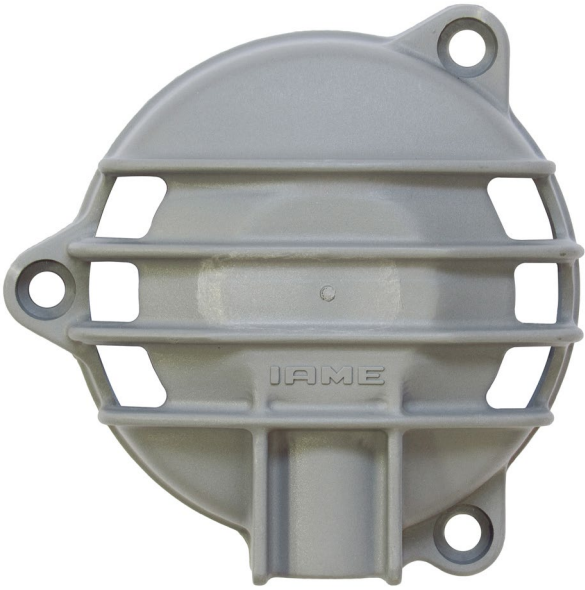

PHOTO OF COMPLETE CRANKSHAFT

EXHAUST without embossed logo



IGNITION COVER IDENTIFICATION MARKING



CLUTCH COVER IDENTIFICATION MARKING



INLET FILTER IDENTIFICATION MARKING



PHOTO IDENTIFICATION OF CONROD – TYPES ALTERNATIVE

TYPE 1



TYPE 2



PARTICULARS WITH ALTERNATIVE NEW LOGO "IAME"

CYLINDER

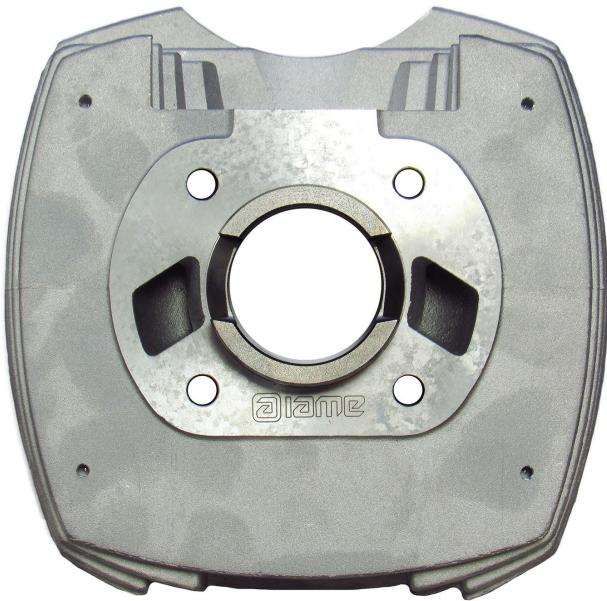

NEW LOGO



NEW LOGO



CYLINDER HEAD

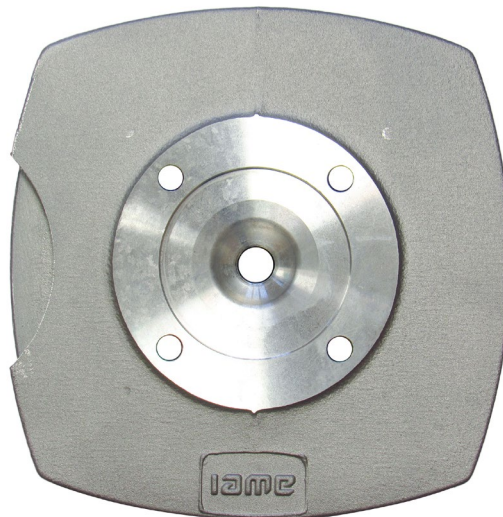

NEW LOGO



PARTICULARS WITH ALTERNATIVE NEW LOGO "IAME"

SEMICARTER IGNITION SIDE

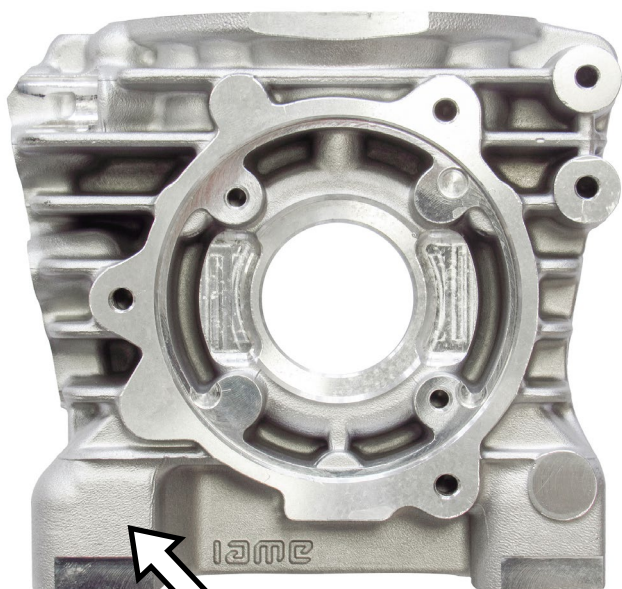

NEW LOGO



FROM 2021 NO "USA" MARKING

SEMICARTER TRANSMISSION SIDE

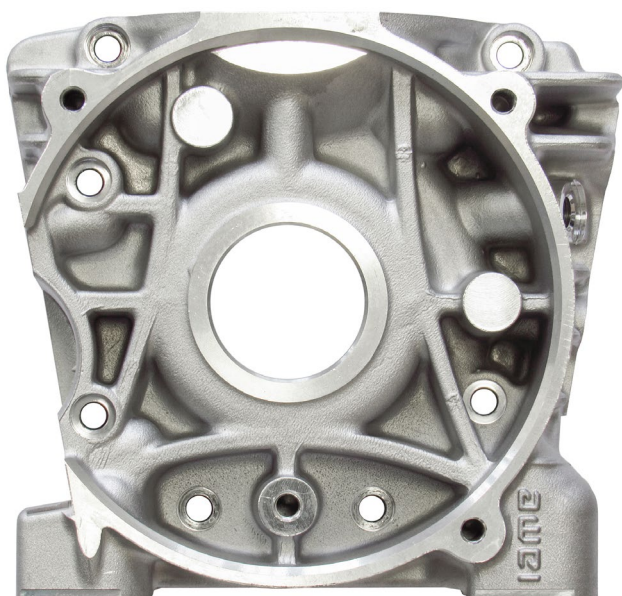

NEW LOGO



PARTICULARS WITH ALTERNATIVE NEW LOGO "IAME"

CLUTCH HUB



NEW LOGO

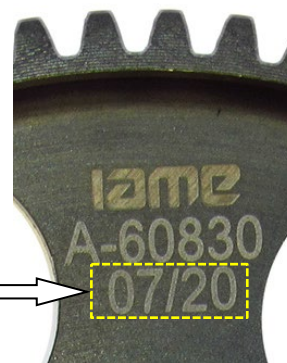

VARIABLE

CLUTCH HUB – TYPE 1



NEW LOGO

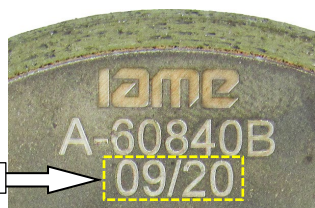

VARIABLE

CLUTCH DRUM



NEW LOGO



PARTICULARS WITH ALTERNATIVE NEW LOGO "IAME"

IGNITION COVER



NEW LOGO



CLUTCH COVER



NEW LOGO



INLET FILTER



NEW LOGO



EXHAUST without embossed logo



NEW LOGO



PARTICULARS WITH ALTERNATIVE NEW LOGO "IAME"

THE OTHERS COMPONENTS OF ENGINE THAT ARE MARKED (LASER OR PUNCHING) UNTIL TODAY WITH LOGO OR WRITTEN "IAME"

I A M E

or

IAME

NOW COULD BE MARKED WITH NEW LOGO "IAME"

IAME

or

IAME

or

IAME



CARBURETTOR
Tillotson HW-31A

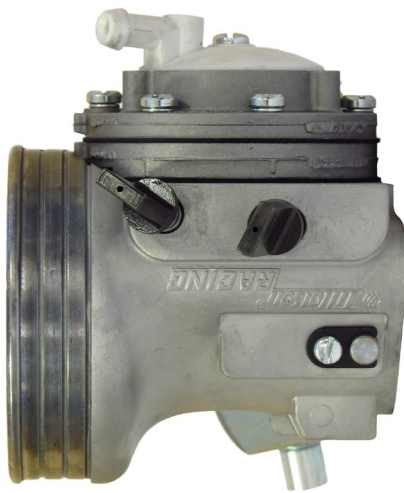

PHOTO OF ADJUSTING SIDE

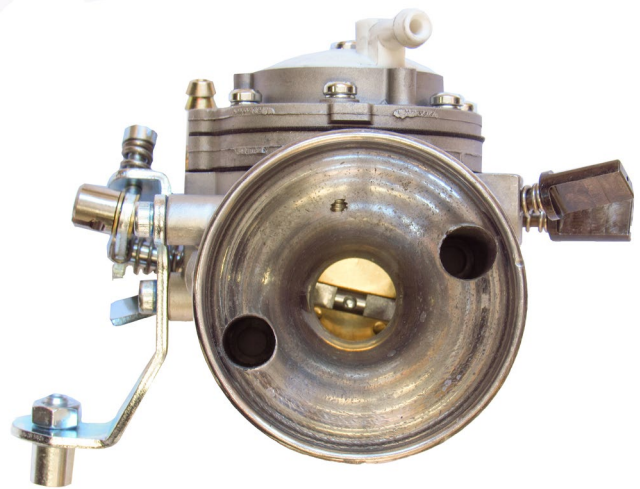
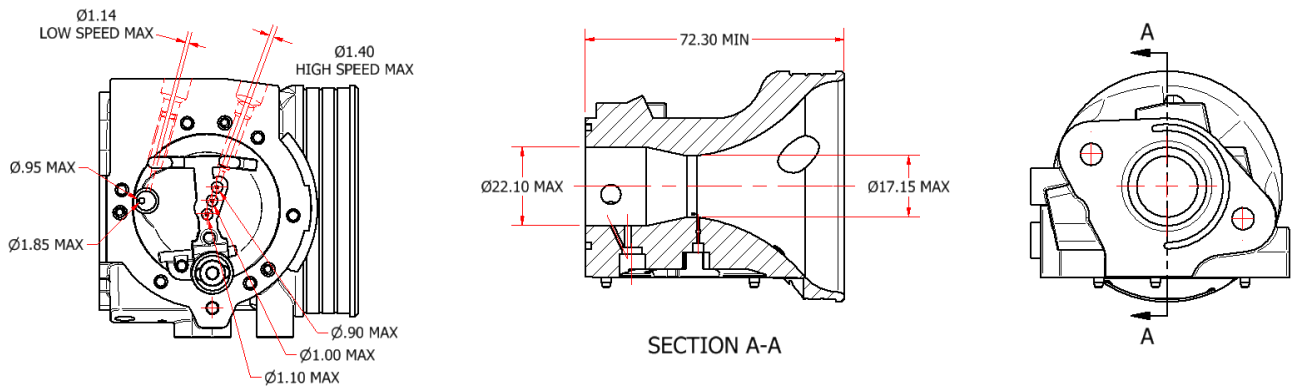

PHOTO OF INLET SIDE

| | |
|--------------|-----------------------|
| Manufacturer | TILLOTSON LTD. |
| Make | TILLOTSON |
| Model | HW-31A |

SECTION VIEW



"IAME" MARKING

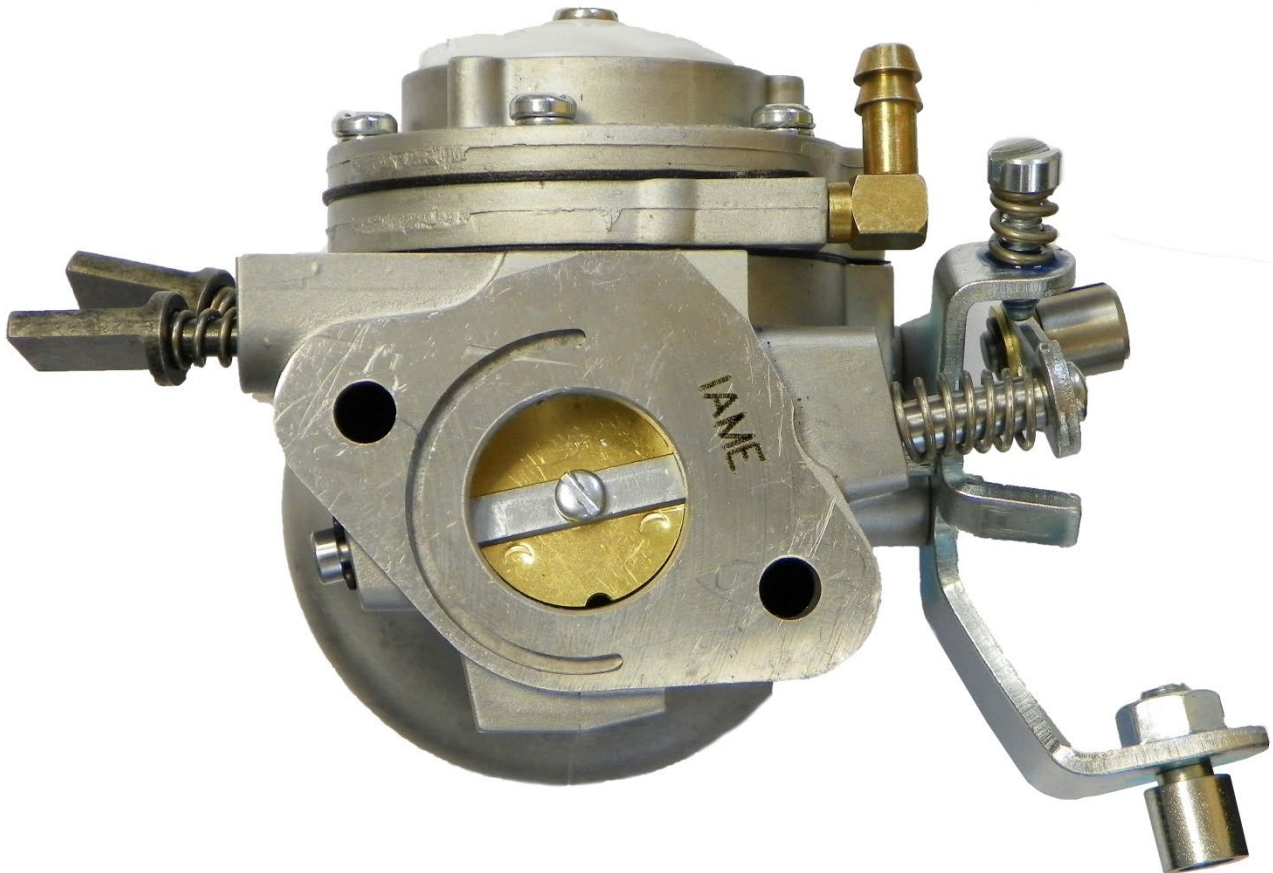

CARBURETTOR DESCRIPTION AND SKETCH OF PARTS

HW-31A

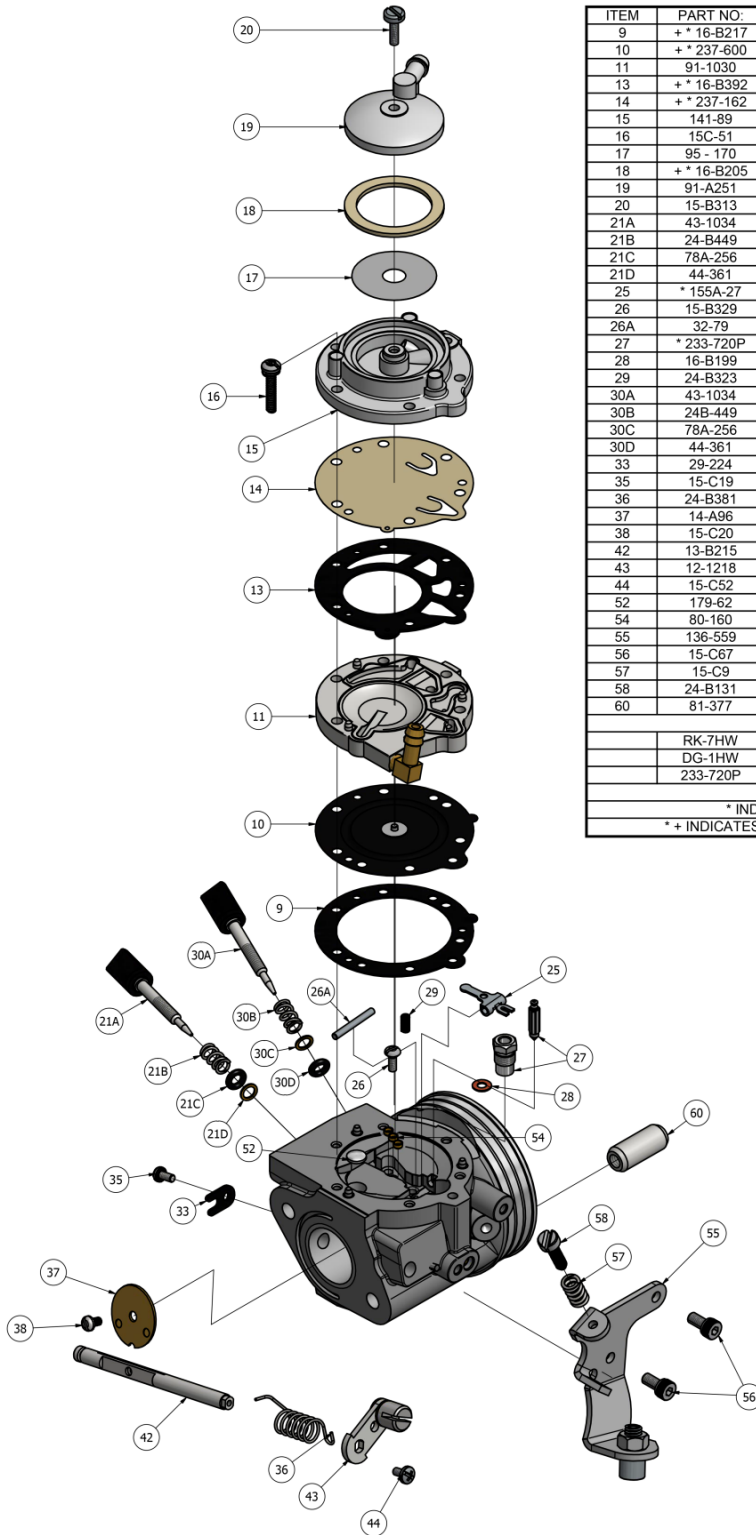

| ITEM | PART NO. | DESCRIPTION | QTY |
|---|-------------|-------------------------------------|-----|
| 9 | + * 16-B217 | DIAPHRAGM GASKET | 1 |
| 10 | + * 237-600 | DIAPHRAGM | 1 |
| 11 | 91-1030 | DIAPHRAGM COVER | 1 |
| 13 | + * 16-B392 | FUEL PUMP GASKET | 1 |
| 14 | + * 237-162 | FUEL PUMP DIAPHRAGM | 1 |
| 15 | 141-89 | FUEL PUMP BODY | 1 |
| 16 | 15C-51 | FUEL PUMP BODY SCREW | 6 |
| 17 | 95 - 170 | FUEL STRAINER SCREEN | 1 |
| 18 | + * 16-B205 | FUEL STRAINER COVER GASKET | 1 |
| 19 | 91-A251 | FUEL STRAINER COVER | 1 |
| 20 | 15-B313 | FUEL STRAINER COVER RETAINING SCREW | 1 |
| 21A | 43-1034 | IDLE MIXTURE SCREW | 1 |
| 21B | 24-B449 | IDLE MIXTURE SCREW SPRING | 1 |
| 21C | 78A-256 | IDLE MIXTURE SCREW WASHER | 1 |
| 21D | 44-361 | IDLE MIXTURE SCREW PACKING | 1 |
| 25 | * 155A-27 | INLET CONTROL LEVER | 1 |
| 26 | 15-B329 | FULCRUM LEVER SCREW | 1 |
| 26A | 32-79 | FULCRUM LEVER PIN | 1 |
| 27 | * 233-720P | INLET NEEDLE & SEAT SET | 1 |
| 28 | 16-B199 | INLET SEAT GASKET | 1 |
| 29 | 24-B323 | INLET TENSION SPRING | 1 |
| 30A | 43-1034 | HIGH SPEED MIXTURE SCREW | 1 |
| 30B | 24B-449 | HIGH SPEED MIXTURE SCREW SPRING | 1 |
| 30C | 78A-256 | HIGH SPEED MIXTURE SCREW WASHER | 1 |
| 30D | 44-361 | HIGH SPEED MIXTURE SCREW PACKING | 1 |
| 33 | 29-224 | THROTTLE SHAFT CLIP | 1 |
| 35 | 15-C19 | THROTTLE SHAFT CLIP RETAINING SCREW | 1 |
| 36 | 24-B381 | THROTTLE RETURN SPRING | 1 |
| 37 | 14-A96 | THROTTLE SHUTTER | 1 |
| 38 | 15-C20 | THROTTLE SHUTTER SCREW | 1 |
| 42 | 13-B215 | THROTTLE SHAFT | 1 |
| 43 | 12-1218 | THROTTLE LEVER ASSEMBLY | 1 |
| 44 | 15-C52 | THROTTLE LEVER RETAINING SCREW | 1 |
| 52 | 179-62 | WELCH PLUG | 1 |
| 54 | 80-160 | MAIN PLUG | 3 |
| 55 | 136-559 | CABLE BRACKET | 1 |
| 56 | 15-C67 | CABLE BRACKET RETAINING SCREW | 2 |
| 57 | 15-C9 | LIMITER SCREW | 2 |
| 58 | 24-B131 | LIMITER SPRING | 2 |
| 60 | 81-377 | CARBURETTOR MOUNTING NUT | 2 |
| RK-7HW | | REPAIR KIT | |
| DG-1HW | | DIAPHRAGM & GASKET (STANDARD) | |
| 233-720P | | INLET NEEDLE & SEAT SET | |
| * INDICATES CONTENTS OF REPAIR KIT | | | |
| *+ INDICATES CONTENTS OF DIAPHRAGM & GASKET SET | | | |



Clash Industrial Estate - Tralee - Ireland
www.tillotson-racing.com



PARTS OF CARBURETTOR

REF.9 - P. N°16-B217
DIAPHRAGM GASKET



Thickness = 0.5 ± 0.1 mm

PUMP DIAPHRAGM GASKET
REF.13 - P. N° 16-B392



Thickness = 0.8 ± 0.1 mm

REF.10 - P. N°237-600
DIAPHRAGM



Thickness = 0.13 ± 0.07 mm

REF.14 - P. N°237-162
PUMP DIAPHRAGM



Thickness = 0.10 ± 0.063 mm

REF.11 - P. N° 91-1031
DIAPHRAGM COVER





Thickness = 6.75 ± 0.15 mm

REF.15 - P. N° 141-89
PUMP COVER

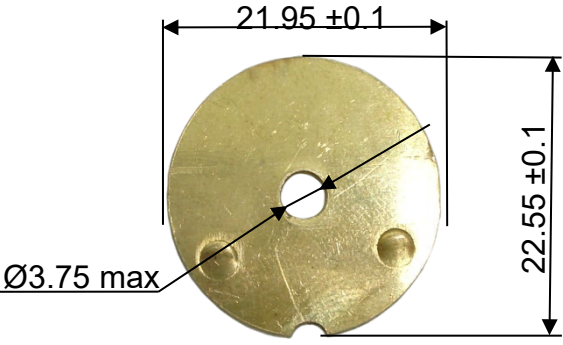
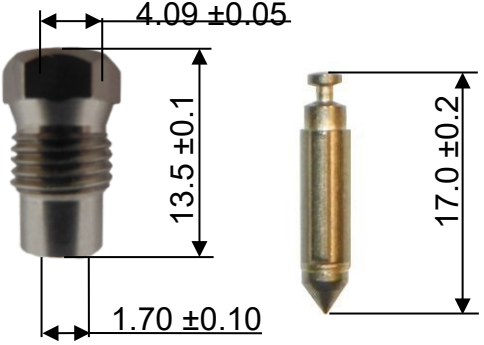
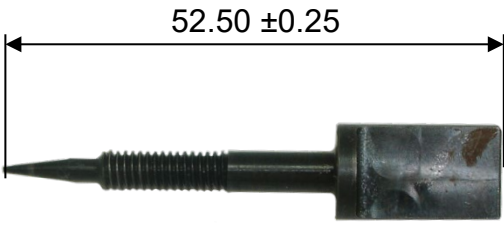

Thickness = 12.5 ± 0.15 mm

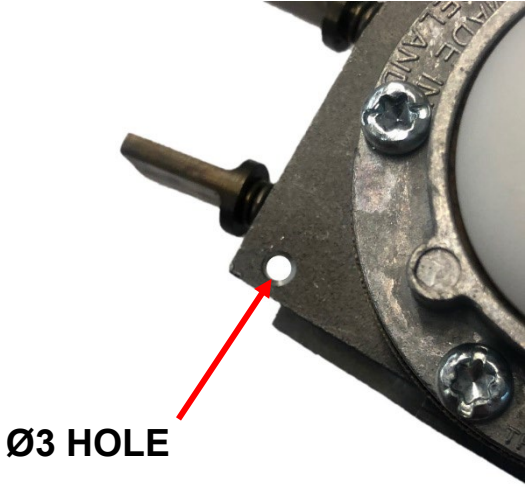
| | |
|--|--|
| <p>REF.37 - P. N° 14-A96 THROTTLE SHUTTER</p>  <p>Thickness = 0.81 ±0.1 mm</p> | <p>REF.27 - P. N° 233-720P SEAT + NEEDLE</p>  |
| <p>REF.21A - P. N° 43-1034 NEEDLE LOW SPEED</p>  | <p>REF.30A - P. N° 43-1034 NEEDLE HIGH SPEED</p>  |
| <p>NEEDLE FUEL ALTERNATIVE</p> | <p>HOLE FOR CARBURETTOR SEALING</p> |
| <p>REF.27 - P. N° 233-720P</p>  | <p>The carburettor can have this hole for sealing.</p>  <p>Ø3 HOLE</p> |